

Building Sketch (Page - 1)

Borrower					
Property Address		7 Brower Cir			
City	Durham	County	Durham	State	NC
Zip Code		27705			
Lender/Client					

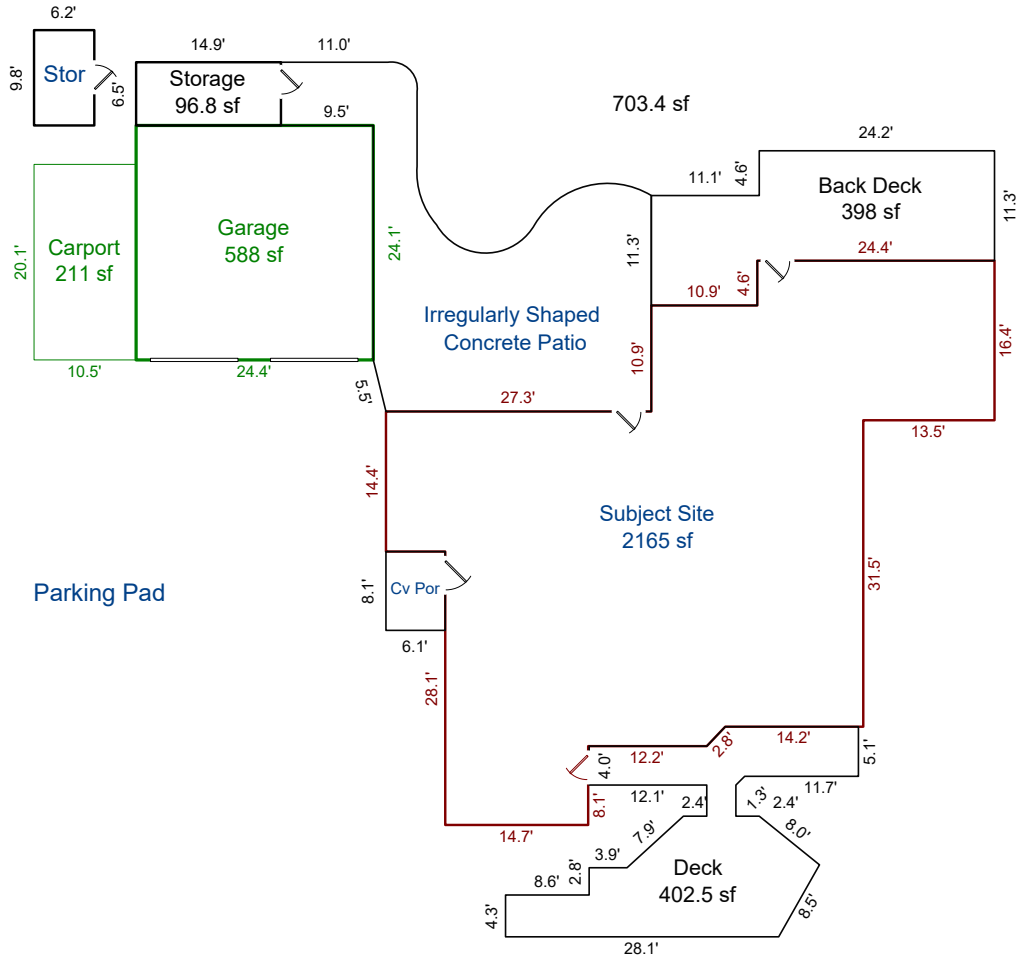

Sketch by ApexSketch

AREA CALCULATIONS SUMMARY						AREA CALCULATIONS BREAKDOWN				
Code	Description	Factor	Net Size	Perimeter	Net Totals	Name	Base x	Height x	Width =	Area
GAR	Garage	1.0	588.0	97.0	799.1					
	Carport	1.0	211.1	61.2						
OTH	Storage	1.0	96.9	42.8	157.6					
	Storage	1.0	60.8	32.0						
P/P	Deck	1.0	402.5	146.0	1553.4					
	Cv Porch	1.0	49.4	28.4						
	Back Deck	1.0	398.0	102.4						
	Irregularly Shap	1.0	703.4	151.1	1553.4					
SITE	Subject Site	1.0	2165.0	240.1	2165.0					
						0 total items (rounded)				0

Building Sketch (Page - 2)

Borrower					
Property Address		7 Brower Cir			
City	Durham	County	Durham	State	NC
Zip Code		27705			
Lender/Client					

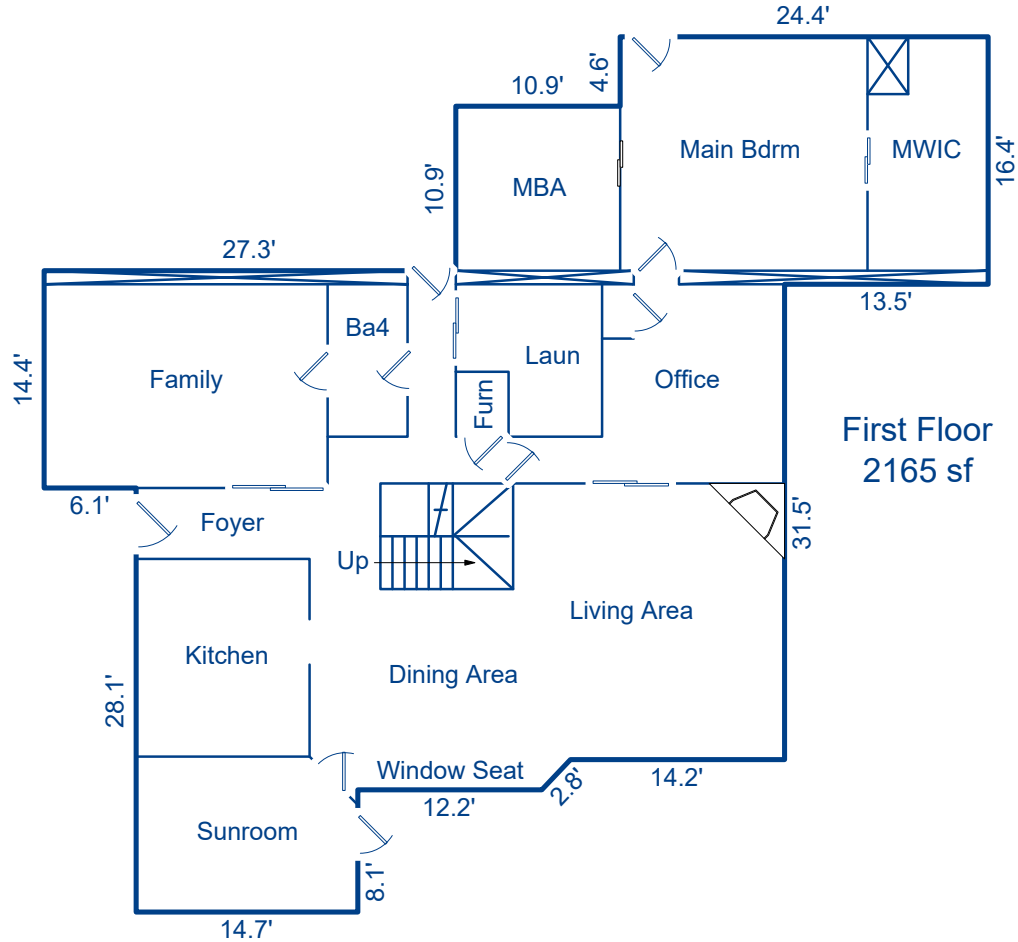

Sketch by ApexSketch

AREA CALCULATIONS SUMMARY						AREA CALCULATIONS BREAKDOWN				
Code	Description	Factor	Net Size	Perimeter	Net Totals	Name	Base x	Height x	Width =	Area
GLA1	First Floor	1.0	2165.0	240.1	2165.0	First Floor		42.5 x	14.7 =	624.8
								14.4 x	6.1 =	87.8
								34.4 x	12.2 =	419.7
								10.9 x	5.7 =	62.1
							0.5 x	2.8 x	1.4 =	1.9
								24.4 x	16.4 =	400.2
								31.5 x	10.9 =	343.4
								43.3 x	5.2 =	225.2
	Net LIVABLE	cnt	1 (rounded)		2,165	8 total items			(rounded)	2,165

Building Sketch (Page - 3)

Borrower					
Property Address		7 Brower Cir			
City	Durham	County	Durham	State	NC
		Zip Code	27705		
Lender/Client					

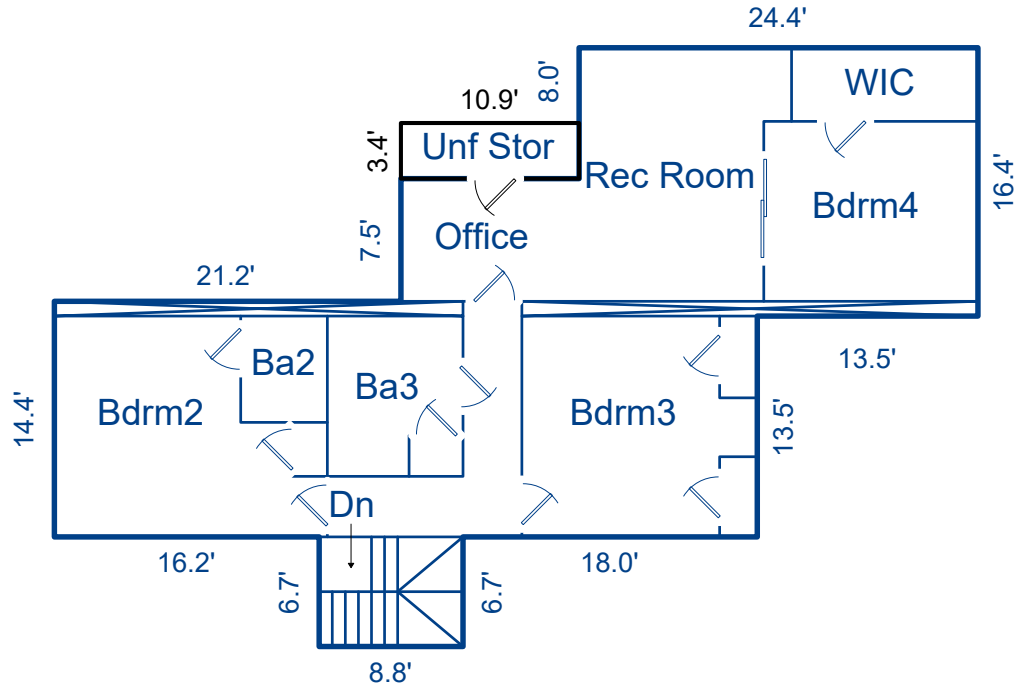

Second Floor
1150.3 sf

Sketch by ApexSketch

AREA CALCULATIONS SUMMARY						AREA CALCULATIONS BREAKDOWN				
Code	Description	Factor	Net Size	Perimeter	Net Totals	Name	Base x	Height x	Width =	Area
GLA2	Second Floor	1.0	1150.3	186.2	1150.3	Second Floor		8.8 x	6.7 =	59.0
OTH	Unf Stor	1.0	37.1	28.6	37.1			35.3 x	8.4 =	296.5
								24.4 x	8.0 =	195.2
								21.2 x	0.9 =	19.1
								43.0 x	13.5 =	580.5
	Net LIVABLE	cnt	1 (rounded)		1,150	5 total items			(rounded)	1,150